

REVISIONS				
REV. NO.	DESCRIPTION	DATE	REV. BY	APPROVED

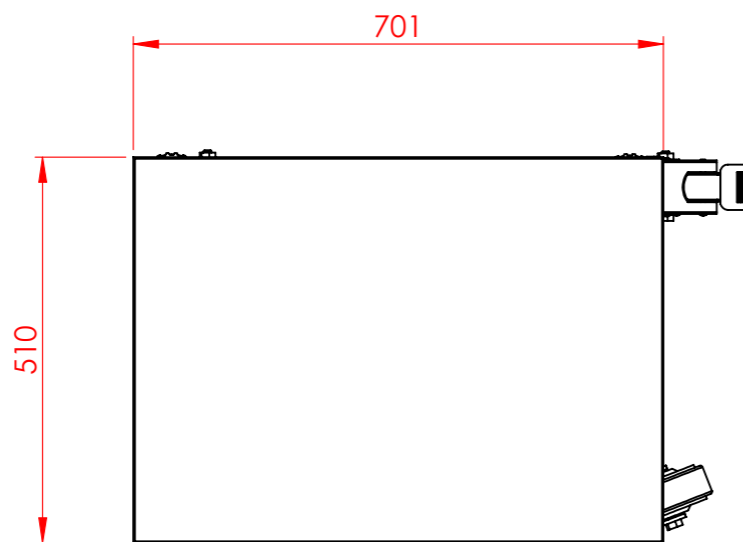
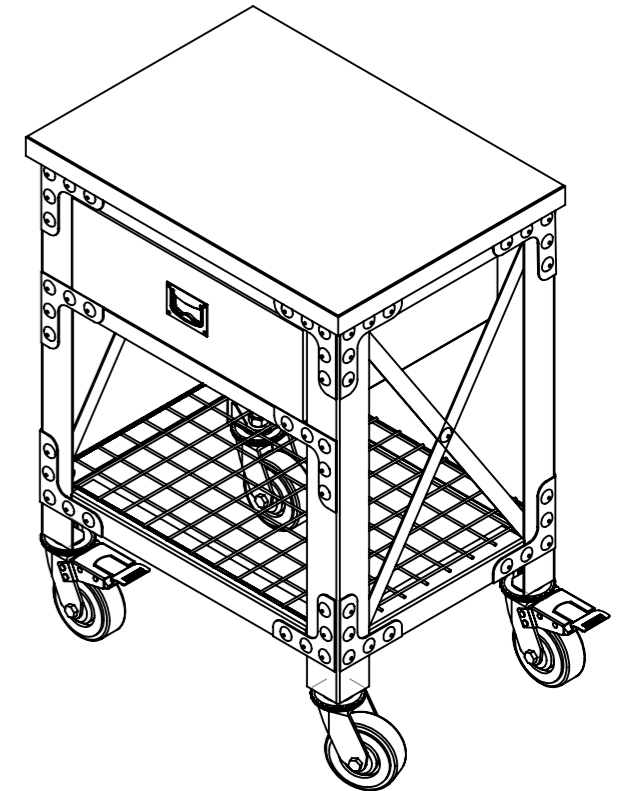
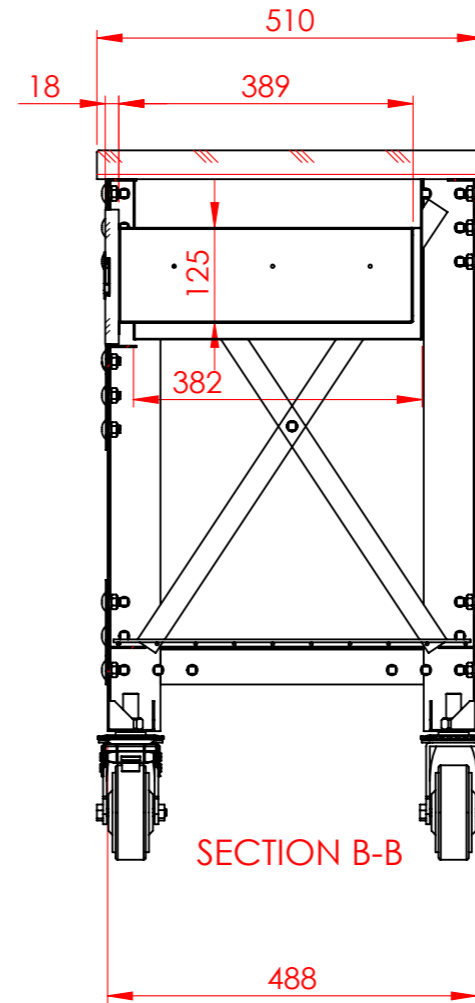
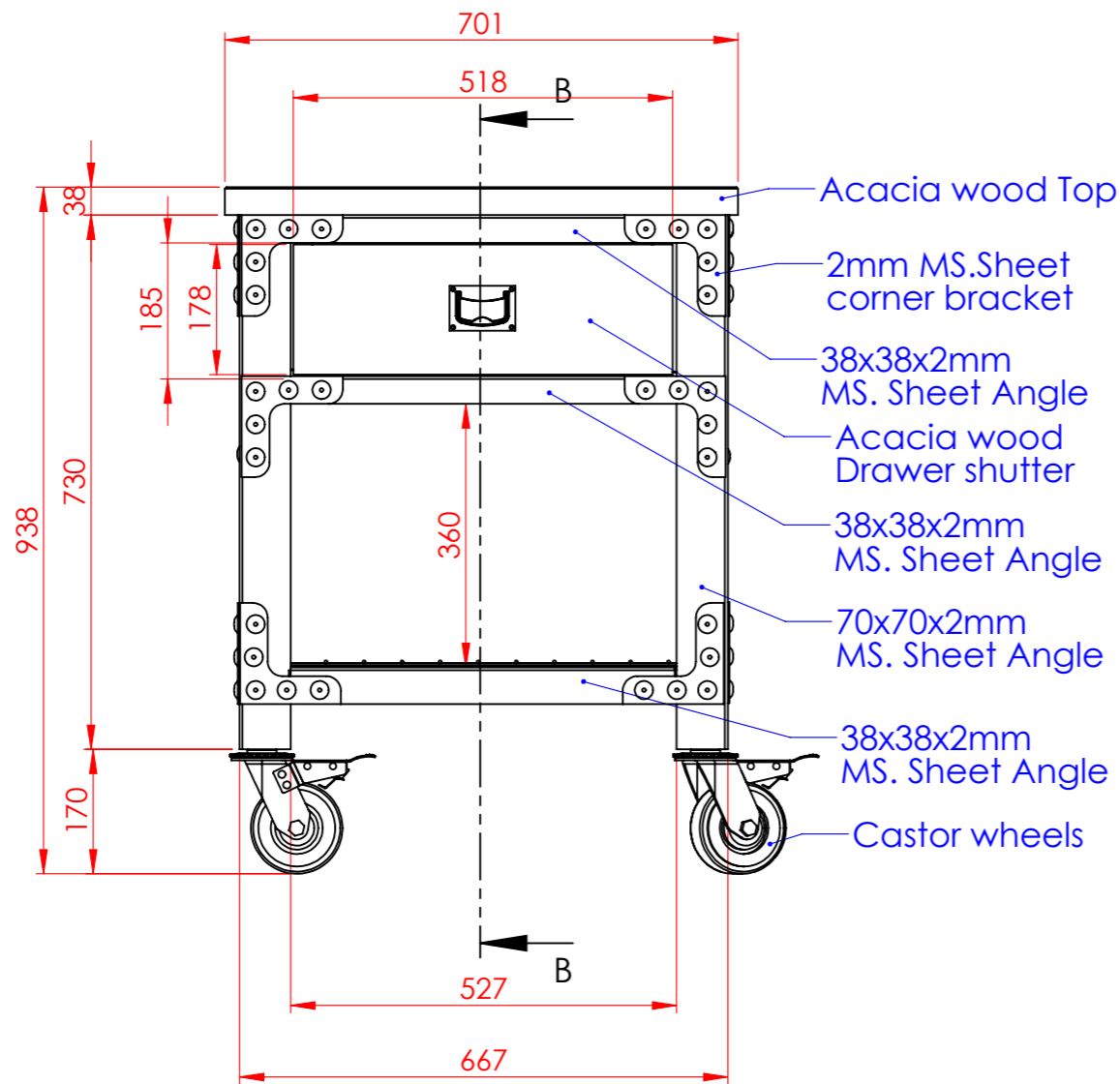

Drawn By	Rashpal Singh	Sheet Thickness: 2.0mm	Weight: ---	S. Area: 5738148.54mm ²
Check By	Mr. Harout	Material: Acacia wood / MS. Sheet	Finish: Power Coated	
Approved By	Mr. Harout	Title: 27.6" Ind. Metal & wood work bench		
Date	4/12/2019			
Drawing Number	IMWB - 27.6- 1	Product :	Work Bench 27.6 Inch	Model:
				701x510x940
General Tolerance : ± 0.1 mm				
Colour	Black	P.O. Box 474039, Jabel Ali, Dubai Investment Park - 1, Dubai (United Arab Emirates) Tel: 04-8841650 Fax: 04-8841934		SHEET 1 OF 20
Quantity	1	ALL DIMENSIONS ARE IN MILLIMETERS AND ALL BEND RADII TO BE MIN. R AT 90° BEND, UNLESS SPECIFIED OTHERWISE THIS DRAWING IS THE PROPERTY OF TSSC, NOT TO BE REPRODUCED AS A PART OR WHOLE WITHOUT PRIOR CONSENT OF TSSC		SCALE N.T.S.
				REV. 00